

Magnescape®

Scale Unit

SR74 / SR75, CH33

Read all the instructions in the manual carefully before use and strictly follow them.
Keep the manual for future references.

Instruction Manual

Safety Precautions

Magnescale Co., Ltd. products are designed in full consideration of safety. However, improper handling during operation or installation is dangerous and may lead to fire, electric shock or other accidents resulting in serious injury or death. In addition, these actions may also worsen machine performance.

Therefore, be sure to observe the following safety precautions in order to prevent these types of accidents, and to read these "Safety Precautions" before operating, installing, maintaining, inspecting, repairing or otherwise working on this unit.

Warning indication meanings

The following indications are used throughout this manual, and their contents should be understood before reading the text.

Warning

Failure to observe these precautions may lead to fire, electric shock or other accidents resulting in serious injury or death.

Caution

Failure to observe these precautions may lead to electric shock or other accidents resulting in injury or damage to surrounding objects.

Warning



- Do not use this unit with voltages other than the specified supply voltages as this may result in fire or electric shock.
- Do not perform installation work with wet hands as this may result in electric shock.



- Do not disassemble or modify the unit as this may result in injury or damage the internal circuits.

Caution



- Be sure to check the machine and device conditions to ensure work safety before working on the machine.



- Be sure to cut off the power supply and other sources of drive power before working on the machine. Failure to do so may result in fire or accidents.



- When turning on the power supply or other sources of drive power to operate the machine, take care not to catch your fingers in peripheral machines and devices.

General Precautions

When using Magnescale Co., Ltd. products, observe the following general precautions along with those given specifically in this manual to ensure proper use of the products.

- Before and during operations, be sure to check that our products function properly.
- Provide adequate safety measures to prevent damages in case our products should develop malfunctions.
- Use outside indicated specifications or purposes and modification of our products will void any warranty of the functions and performance as specified of our products.
- When using our products in combination with other equipment, the functions and performance as noted in this manual may not be attained, depending upon operating environmental conditions. Make full study of the compatibility in advance.

[For U.S.A. and Canada]

THIS CLASS A DIGITAL DEVICE COMPLIES WITH PART15 OF THE FCC RULES AND THE CANADIAN ICES-003. OPERATION IS SUBJECT TO THE FOLLOWING TWO CONDITIONS.

- (1) THIS DEVICE MAY NOT CAUSE HARMFUL INTERFERENCE, AND
- (2) THIS DEVICE MUST ACCEPT ANY INTERFERENCE RECEIVED, INCLUDING INTERFERENCE THAT MAY CAUSE UNDERSIGNED OPERATION.

CET APPAREIL NUMÉRIQUE DE LA CLASSE A EST CONFORME À LA NORME NMB-003 DU CANADA.

[For EU and EFTA countries]

CE Notice

Marking by the symbol CE indicates compliance with the EMC directive of the European Community. This marking shows conformity to the following technical standards.

EN 55011 Group 1 Class A/1998 A1/1999 A2/2002 :

"Limits and methods of measurement of radio disturbance characteristics of industrial, scientific and medical (ISM) radio-frequency equipment"

EN 61000-6-2/2001 :

"Electromagnetic compatibility (EMC) - Part 6-2 : Generic standards - Immunity for industrial environments"

警告

本装置を機械指令 (EN 60204-1) の適合を受ける機器にご使用の場合は、その規格に適合するように方策を講じてから、ご使用ください。

Warning

When using this device with equipment governed by Machine Directives EN 60204-1, measures should be taken to ensure conformance with those directives.

Warnung

Wenn dieses Gerät mit Ausrüstungsteilen verwendet wird, die von den Maschinenrichtlinien EN 60204-1 geregelt werden, müssen Maßnahmen ergriffen werden, um eine Übereinstimmung mit diesen Normen zu gewährleisten.

Contents

1. Overview	1
1-1. System Configuration	1
1-2. Features	1
2. Installation	2
2-1. Names of Parts	2
2-2. Installing the Scale and Slider	2
3. Scale (SR74/75) and Connecting Cable	7
3-1. Scale (SR74/75)	7
3-1-1. Output Signal (SR74)	7
3-1-2. Output Signal (SR75)	9
3-1-3. Power Supply	9
3-2. Connecting Cable (CH33)	10
3-2-1. CH33 (cable with unterminated end) Signal Specifications	10
4. Measures for Operating Environments	11
4-1. Air purge	11
4-2. Oil Lubrication	14
5. Specifications	16
5-1. Scale	16
5-2. Connecting Cables	18
5-3. Accessories	18
6. Dimensional Diagrams	19

1. Overview

This product is a scale system that outputs position signals for machine tools and other equipment that require high-precision positioning.

1-1. System Configuration

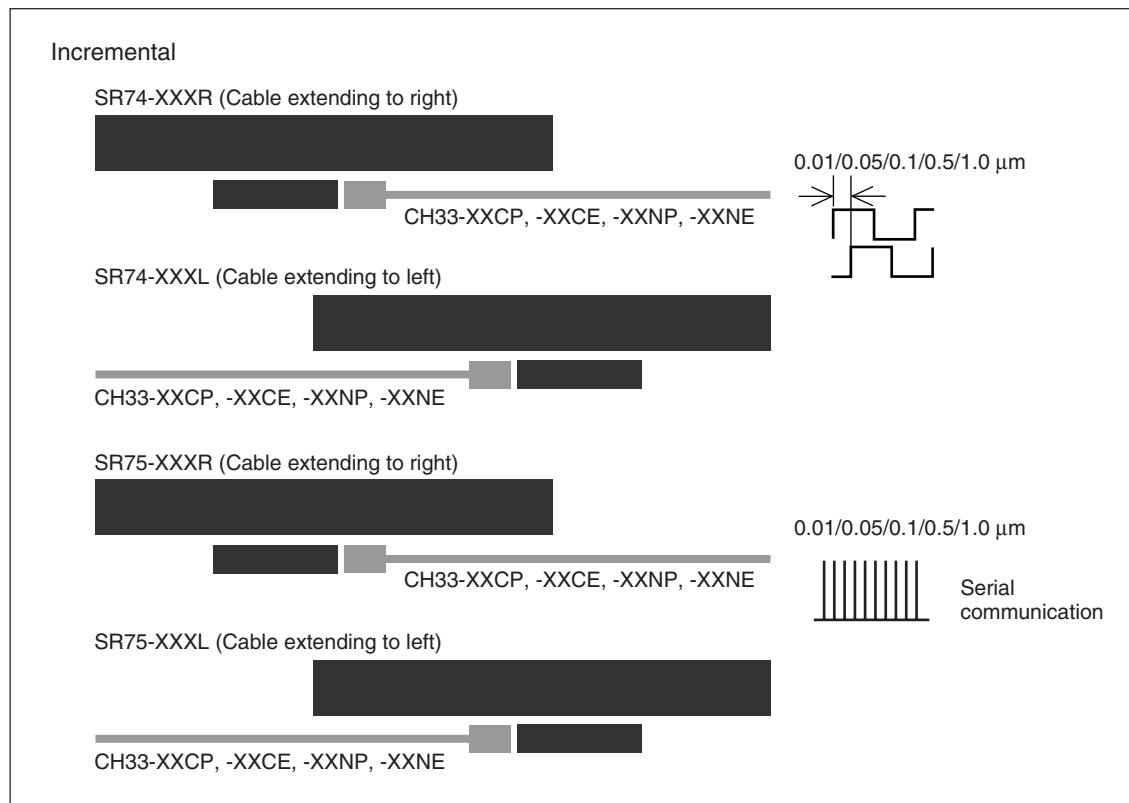

Fig. 1-1

Model name	Product name	Description	Remarks
SR74-XXX	MAGNESCALE	A/B quadrature signal output	XXX: Measuring length (cm)
SR75-XXX	MAGNESCALE	Serial communication signal output	
CH33-XXCP	Cable with unterminated end	Cable sheath: PVC With cable armor	XX: Cable length (m)
CH33-XXCE	Cable with unterminated end	Cable sheath: Polyurethane With cable armor	
CH33-XXNP	Cable with unterminated end	Cable sheath: PVC Without cable armor	
CH33-XXNE	Cable with unterminated end	Cable sheath: Polyurethane Without cable armor	

1-2. Features

- The scale unit has a compact cross-section and uses iron channels in the case for superior rigidity.
- The scale and connecting cables are separated by the connector on the scale slider unit for easy installation.
- Includes a built-in function for correcting variations in scale signal levels for enabling high-precision positioning. High-precision correction function developed exclusively by Magnescale Co., Ltd. is used to realize high precision and high resolution.

2. Installation

For the installation dimensions, refer to section 6, “Dimensional Diagrams.”

2-1. Names of Parts

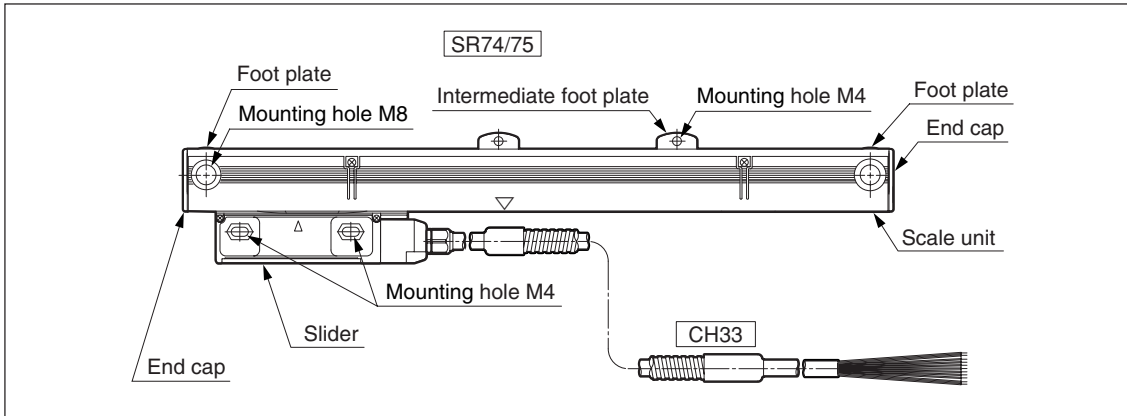

2-2. Installing the Scale and Slider

Notes

- Do not turn on the power before installing the scale.
- Install the scale with the opening on the scale unit facing downward. If the opening cannot be turned downward, it should face horizontally. Never install it facing upward. (Fig. 2-1)

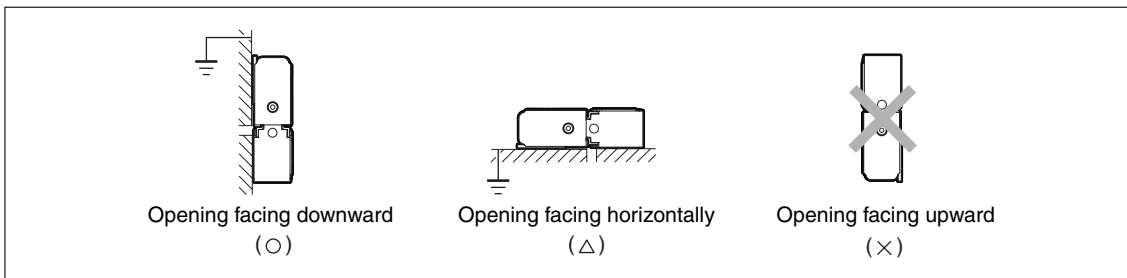

Fig. 2-1

- Remove off the coating around the tap hole to ground the scale unit using the installation surface contact with the scale.
- Be aware that the scale will be damaged if slider moved outside the measuring length (ML).
- In environments where coolant can splash directly on the scale, be sure to mount a cover on the scale to protect the scale from splashing. (Fig. 2-2)

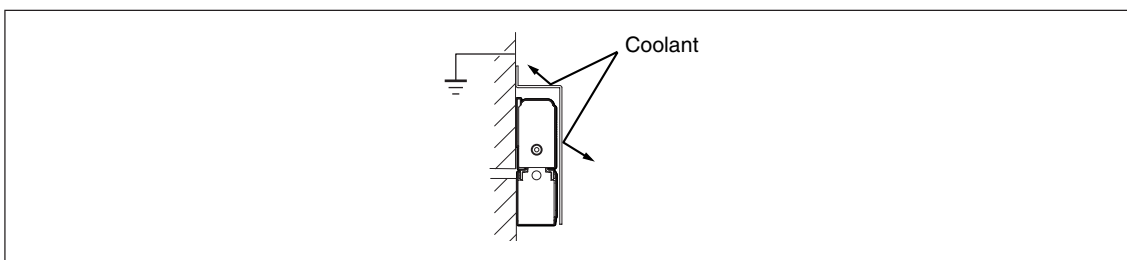

Fig. 2-2

- The slider holders are used to secure the slider in place during transport. They are not guides for installation.
- Do not take off the slider holders, if possible, until immediately before securing the slider.
 - Even if the slider holders are removed, the plastic hook provided on the slider allows the slider to maintain an approximate positional relationship with the scale unit.
 - The plastic hook can come off if the slider is forcibly twisted or other excessive force is applied. If the plastic hook comes off, return the plastic hook back to its original position before performing the installation.
- After removing the slider holder, be sure to take off the clamp nuts remaining on the scale.

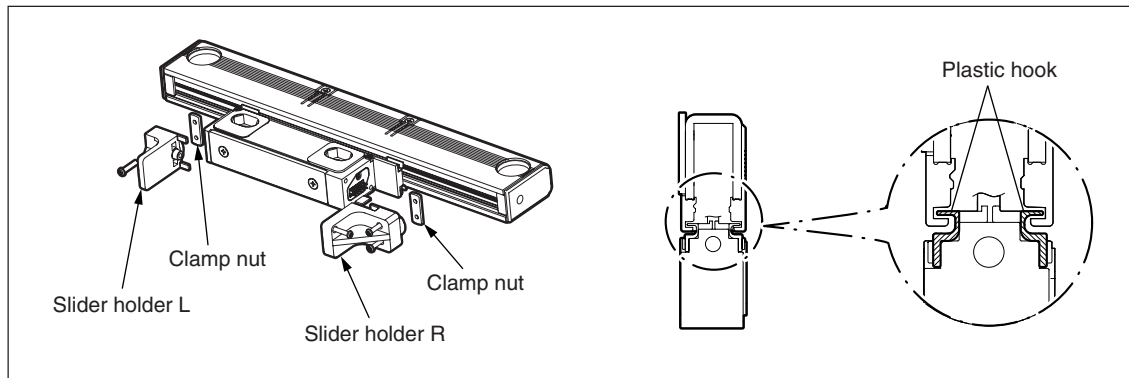

Fig. 2-3

- Before installing the scale, check that the alignment of the installation surface (or installation brackets) is within the standards.
- Use a scale installation bracket, where applicable, having a length covering the entire scale length. The parallelism of the scale may be harmed if only using a bracket divided for the installation section.
- The foot plates on both ends and intermediate foot plate installed on the scale unit are used as the installation guides.
- Loosely turn the mounting screws first. Determine the alignment and then tighten the screws to fasten the scale. (See Fig. 2-4)

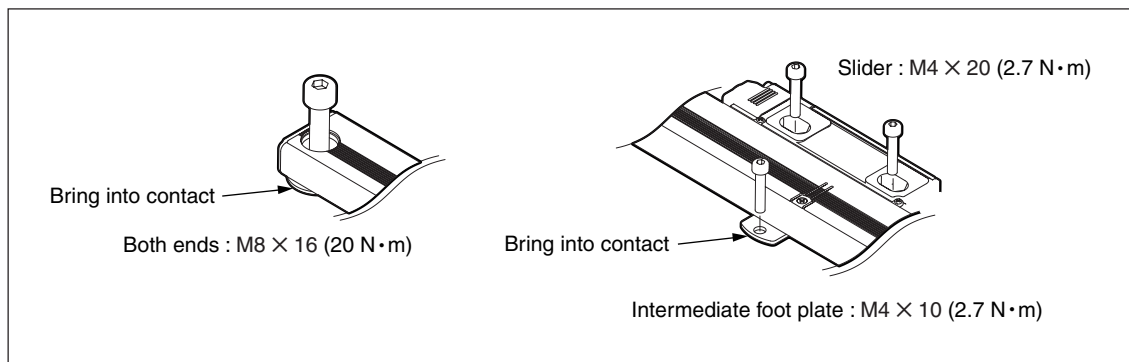

Fig. 2-4

Installation example

Example 1 (recommended): Installation when a stop surface of the scale and slider is made with the bracket

Scale installation accuracy is improved when a stop surface is made. This also simplifies reinstallation of the scale.

1. Check and adjust the scale bracket's parallelism with respect to the machine guide, and then secure in place.

As shown in the figure, adjust the parallelism over the entire bracket length even when making a difference in levels on the scale installation surface.

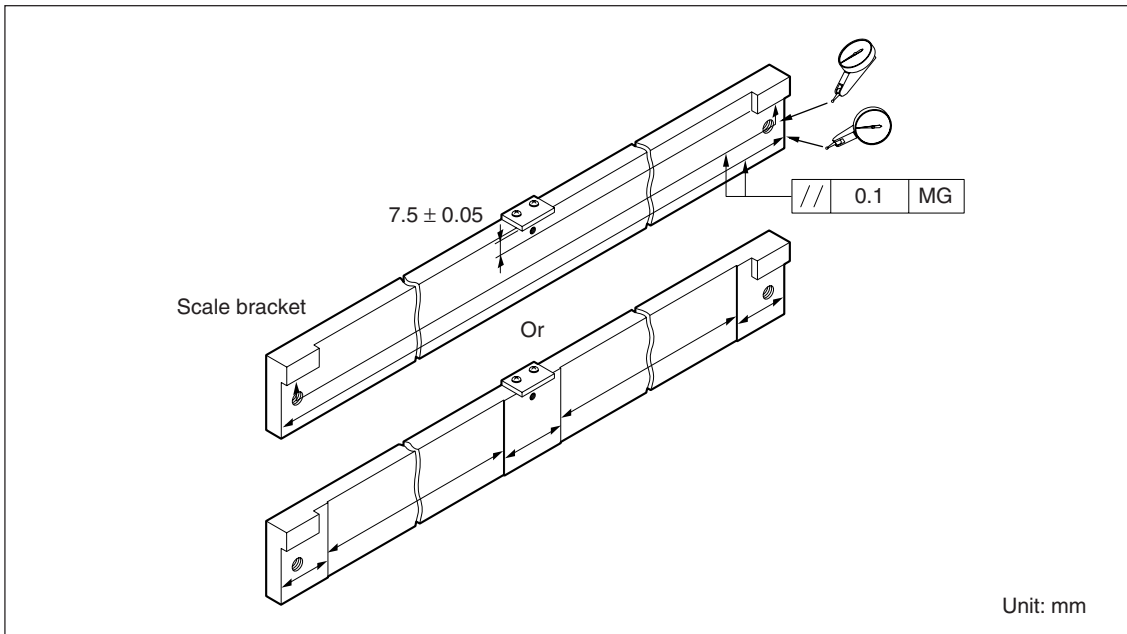

Fig. 2-5

2. Check and adjust the height and parallelism of the slider bracket, and then secure in place.

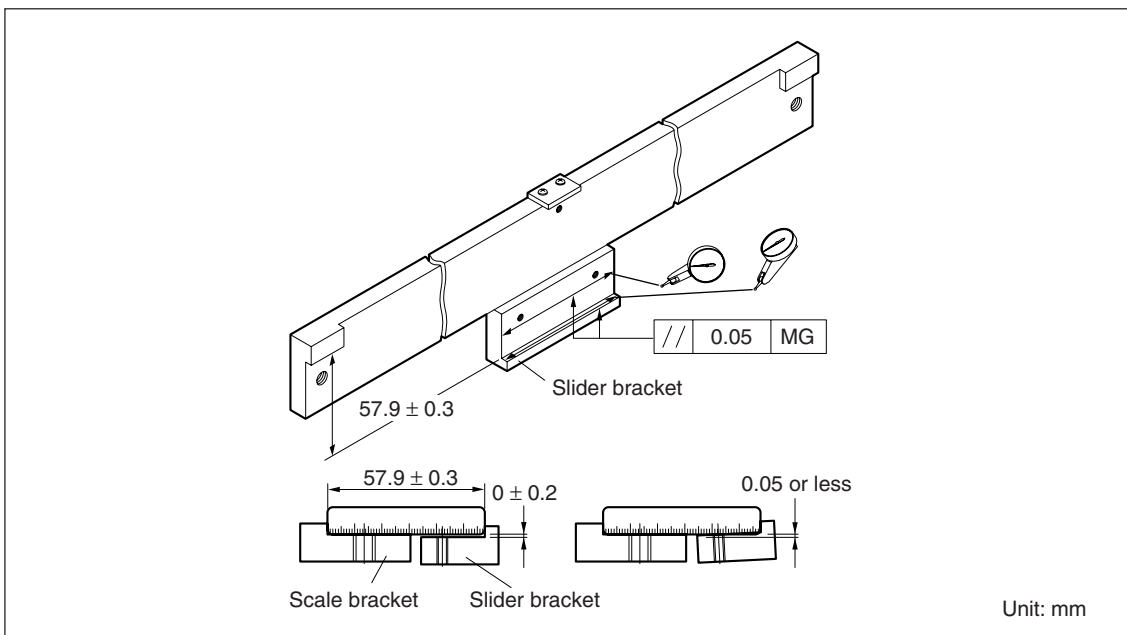

Fig. 2-6

3. Bring the scale into contact with the stop surfaces and install.

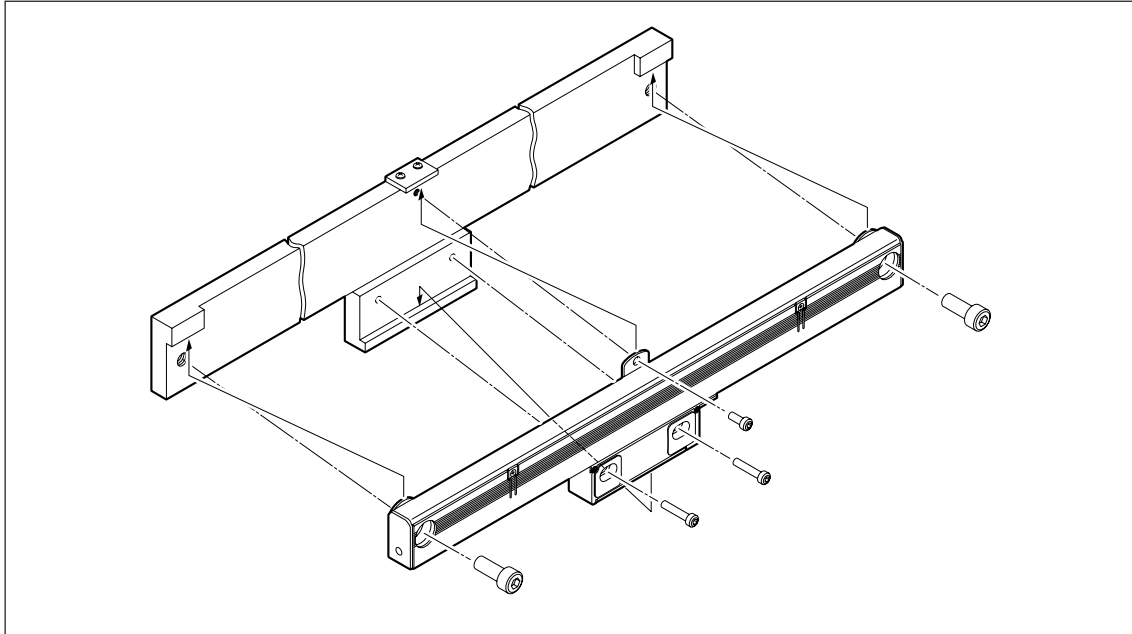

Fig. 2-7

Example 2: Installation when a stop surface of the scale and slider is not made with the bracket

1. Adjust the parallelism of the scale bracket and slider bracket with respect to the machine guide, and then secure in place. Adjust the height and parallelism of the slider bracket with respect to the scale bracket, and then secure in place.

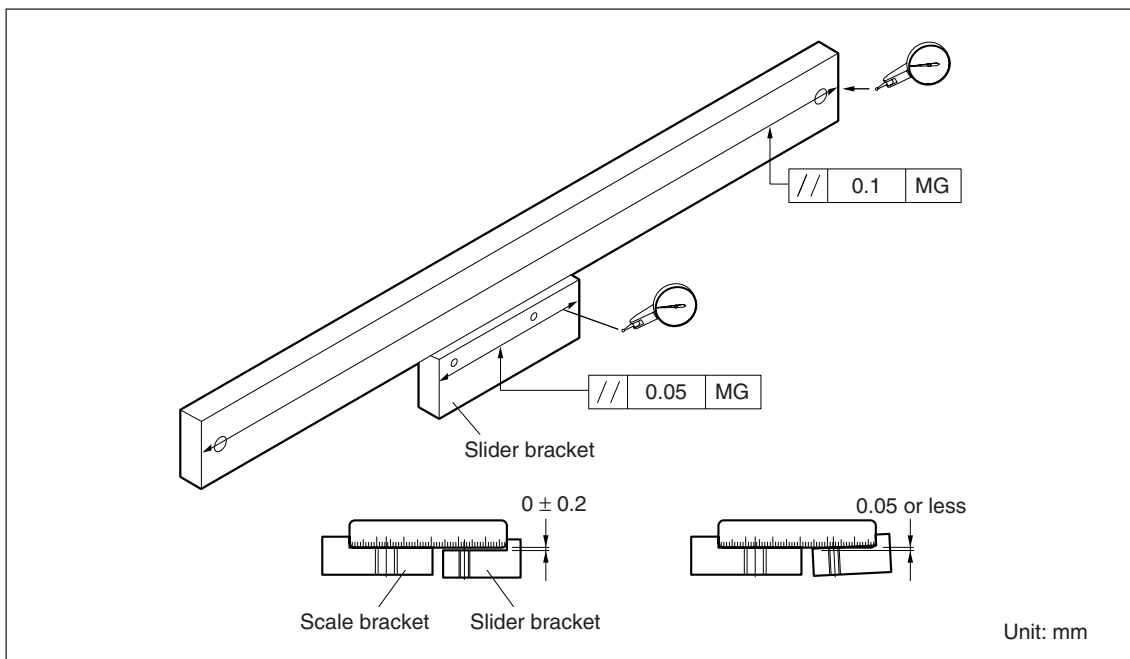

Fig. 2-8

2. Adjust the parallelism with respect to the machine guide of the scale rear while measuring* the scale rear with a dial gauge. Tighten the set screws.

***<Measurement method>**

Measure at two points where the measurement distance is as wide as possible and at the same distance from the right and left scale ends. If using a scale with intermediate foot plate, be sure to also measure the intermediate foot plate.

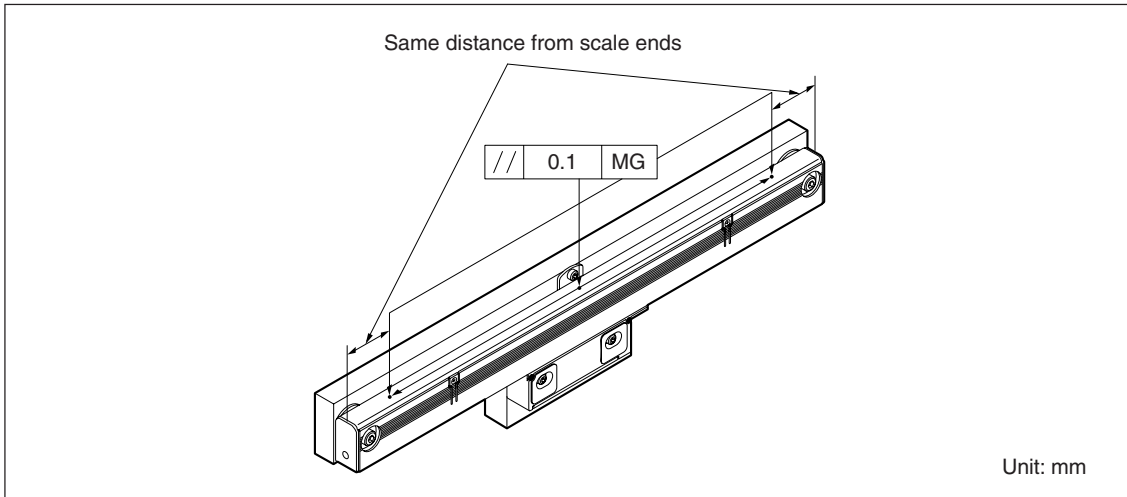

Fig. 2-9

3. Insert the supplied spacer (t = 1.0 mm) in the space between the scale and slider, and then adjust the slider position while bringing the slider into contact with the scale.

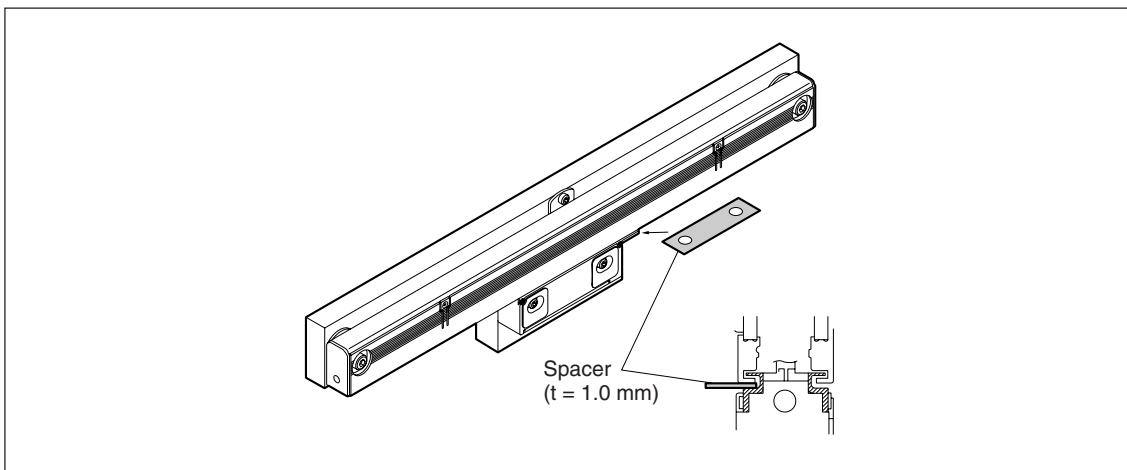

Fig. 2-10

3. Scale (SR74/75) and Connecting Cable

- A steel channel is used for the scale case for realizing a compact cross-sectional shape with high rigidity that also provides a magnetic shielding effect.
- The scale unit and connecting cable are separated by the connector of the scale slider unit. The cable extension direction to the right or left is selected when ordering.
- All models use direct output.

3-1. Scale (SR74/75)

3-1-1. Output Signal (SR74)

When the slider is moved in the direction of the arrow, the A signal is ahead when the polarity is “positive,” and B signal is ahead when the polarity is “negative.”

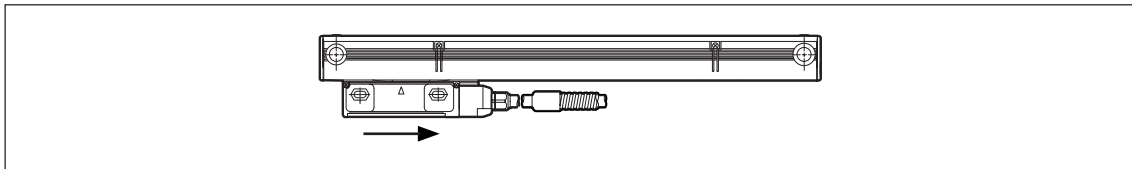

Fig. 3-1

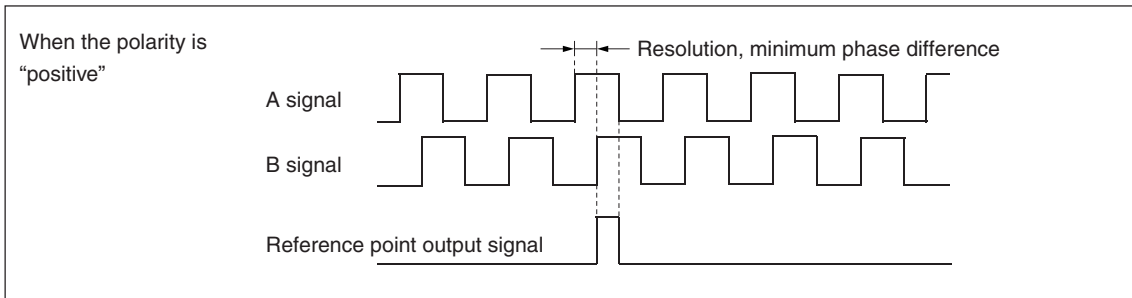

Fig. 3-2

The scale movement is detected every 50 ns, and a signal is output at a phase differential time proportional to the movement. The phase differential time varies in integer multiples of 50 ns.

An alarm signal is output, and the A/B quadrature signal becomes high impedance in the following cases. The alarm is reset by turning the power off and then on again.

- When the phase differential time of the A/B quadrature signal is less than the minimum phase differential time setting
- When noise or other malfunctions occur

Maximum response speed (m/min)

Resolution (μm)	Minimum phase differential time setting (ns)					
	50	100	150	200	250	300
0.01	5	3	2	1	1	1
0.05	25	12	8	6	5	4
0.1	50	25	16	12	10	8
0.5	180	125	80	60	50	40
1	180	180	160	120	100	80

Please contact our sales representative for minimum phase differential times other than those above.

Recommended Receiving Circuit

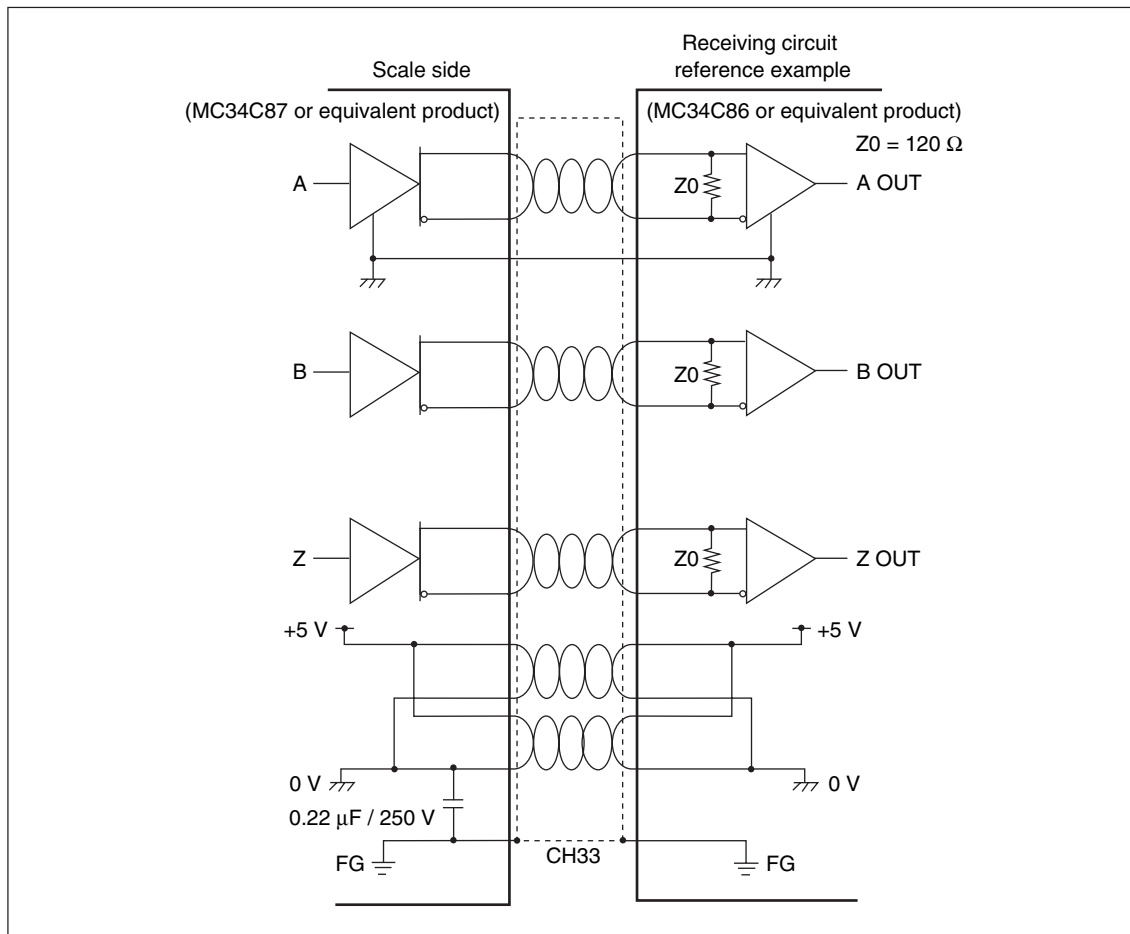

Fig. 3-3

3-1-2. Output Signal (SR75)

When the slider is moved in the direction of the arrow, the signal is addition when the polarity is “positive,” and it is subtraction when the polarity is “negative.” The polarity is selected when ordering.

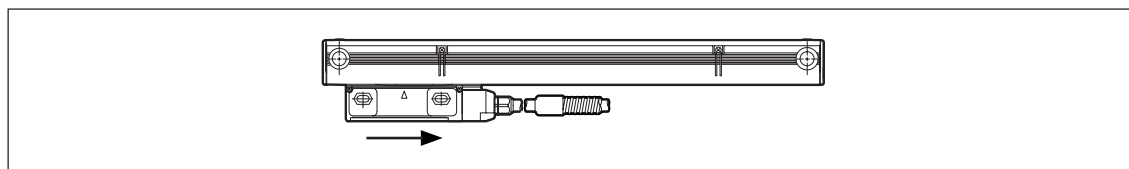

Fig. 3-4

The scale uses incremental serial bidirectional communication protocol for conducting data communication with controllers. For information on supported company protocols, contact your Magnescale Co., Ltd. sales representative.

Communication circuit side

When connecting to a controller, be sure to follow the connection procedure of the controller manufacturer.

3-1-3. Power Supply

Use a power supply that satisfies the specifications below.

Use of a power supply with a short-circuit protection device is recommended.

SR74 / SR75	
Supply voltage	DC 4.75 - 5.25 V
Consumption current	200 mA or less
Inrush current	2 A or less*
Ripple voltage	50 mVp-p or less

*: When the power supply rising time is 10 ms.

Note

Do not turn on the power before installing the scale.

The scale begins functioning normally approximately 0.6 seconds after the power is turned on.

Also, a signal may be output momentarily when the power is turned on or off, and this signal can cause the entire system to malfunction.

To prevent this, be sure to follow the proper power-on and power-off procedures.

Power-on procedure

1. Turn on the power for the scale.
2. Turn on the power for the receiving device.

Power-off procedure

1. Turn off the receiving device.
2. Turn off the scale.

3-2. Connecting Cable (CH33)

Note

Be sure to use CH33 to satisfy safety standards.

3-2-1. CH33 (cable with unterminated end) Signal Specifications

Cable color	SR74	SR75	
		Full duplex	Half duplex
Brown	0 V	0 V	0 V
Black	0 V	0 V	0 V
Green	+5 V	+5 V	+5 V
Violet	+5 V	+5 V	+5 V
Blue	A	CNT ^(Note 1)	CNT ^(Note 1)
Yellow	-A	N.C. ^(Note 2)	N.C. ^(Note 2)
Orange	B	SD	N.C. ^(Note 2)
Gray	-B	-SD	N.C. ^(Note 2)
Red	Z	RQ	SD/RQ
White	-Z	-RQ	-SD/-RQ

(Note 1) The CNT terminal is for service maintenance. Do not connect.

(Note 2) N.C.: Signal is not connected.

There are always two cables each for +5 V and 0 V, and so be sure to connect these cables in pairs. If only one cable is connected, the scale may not operate due to the voltage drop in the cable.

4. Measures for Operating Environments

4-1. Air purge

In the standard configuration, an M5 tap hole for air purging is provided in the end cap section of the scale. Air can be injected into the scale unit to reduce the effects of the environments shown below.

The actual effects, however, will vary depending on operating conditions. Therefore, be sure to fully check the effects before using air purge.

- Use in dusty area
- Use in locations close to coolants

Air Tube Route and Device Configuration

Prepare the devices as shown in the figure below, and air is injected into the scale by connecting the air tubes.

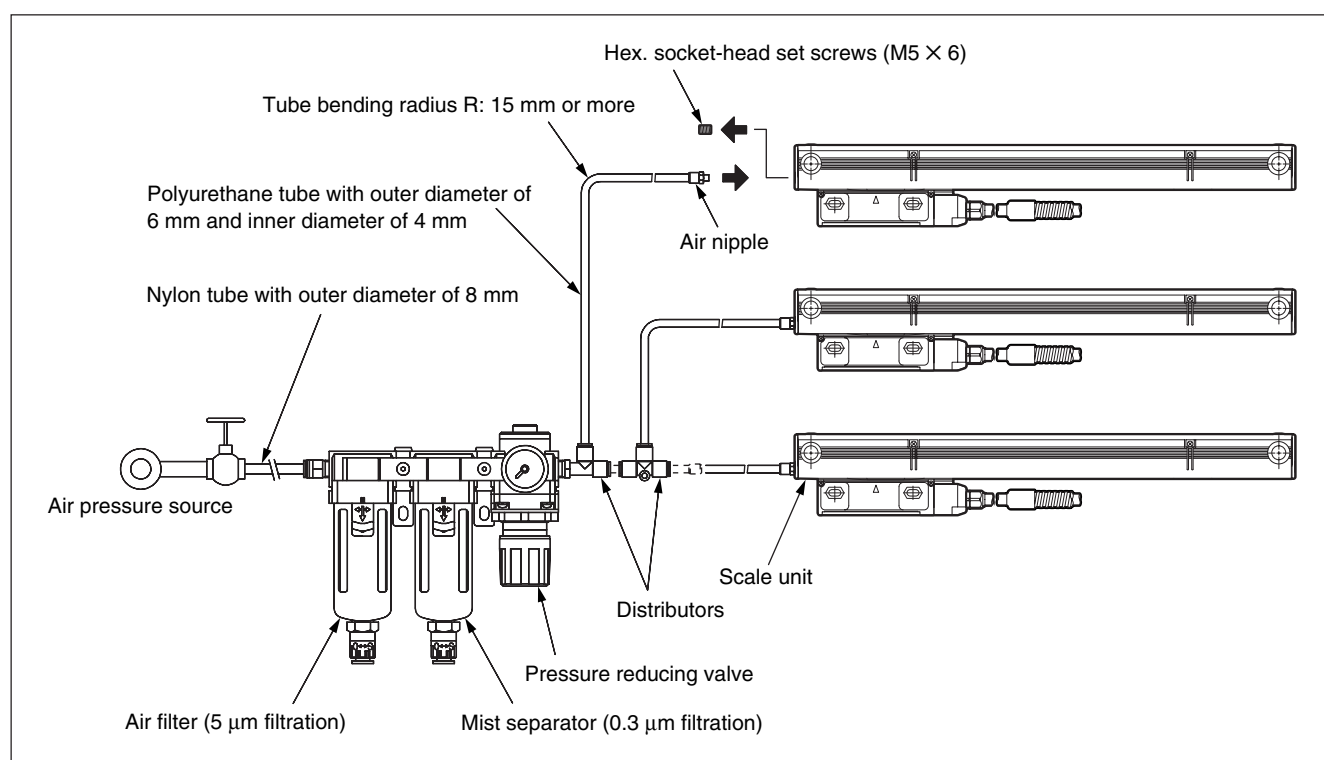

Fig. 4-1

The customer must obtain the air supply unit and input/output air tubes. The recommended air supply unit specifications and main components are shown in the table below.

Specifications

Guaranteed pressure resistance	1.5 MPa
Maximum operating pressure	1020 kPa
Minimum operating pressure	20 kPa
Pressure setting range	20 to 200 kPa
Operating temperature and operating fluid temperature	-5 to 60 °C (no freezing allowed)
Filtration	Air filter: 5 µm Mist separator: 0.3 µm
Pressure gauge connection port	2 × Rc (PT) 1/8
Tube connection port	Input side: Tube outer diameter of 8 mm (1 location), Output side: Tube outer diameter of 6 mm (3 locations)
Auto drain differential pressure	150 to 1020 kPa

Main comsents

Manufacturer	Model	Name	Quantity
SMC Corporation	AF3000-02C	Air filter	1
SMC Corporation	AFM3000-02C	Mist separator	1
SMC Corporation	AR3000-02G-1	Regulator with 200 kPa pressure gauge	1
SMC Corporation	Y30L	Spacer assembly with L-type bracket	2
SMC Corporation	KQ2S06-M5	Air nipple	1

Note

The air filter and mist separator should incorporate a float-type auto drain (NC) mechanism. Use a drain tube with a diameter of at least 4 mm and length of 5 m or less. Set the tubes so that there is no rising.

Tube Layout Notes

Tube arrangement

Use tubes with a bending radius of at least 15 mm and make sure that there are no sharp bends. Also, if the tubes are laid parallel within the ducts for the electrical wiring or hydraulic tubes, be careful that the tubes are not crushed by the movement of the ducts.

Tube length

To inject air simultaneously into multiple scales, make the tubes the same length from the distributor of the air supply unit to each scale so that the injection air pressure is uniform for each scale.

Pressure setting and tube length for pressure reducing valve

If the air injection pressure for each scale is around 20 ± 10 kPa, the air in the scale can be maintained at a low humidity. However, setting the air injection pressure only via the pressure reducing valve will not result in an air injection pressure of 20 ± 10 kPa due to pressure losses stemming from the tube length.

Refer to graph below to determine the pressure setting of the pressure reducing valve.

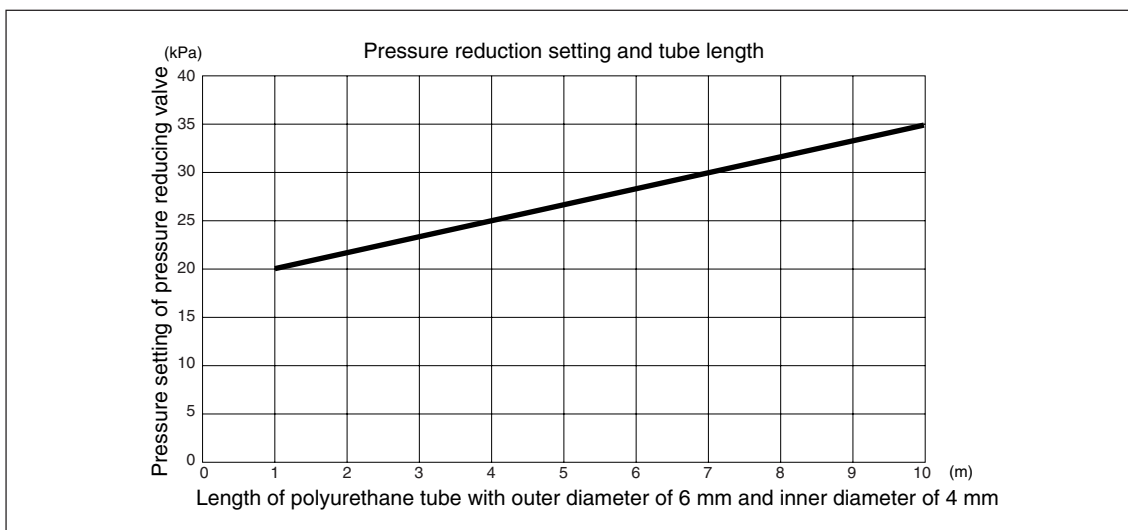

Fig. 4-2

This graph illustrates the relationship between the regulator pressure setting and tube length when the air injection pressure is 20 kPa. The tube length here is considered to be the length from the distributor of the air supply unit to the scale. When the air injection pressure is 20 kPa, the air consumption amount per scale unit is approximately 30 Nℓ/min.

Tube flushing

Flush the tube from the air pressure source to the air supply unit connectors and each scale connector. Flushing cleans the tubes, prevents the embedding of foreign objects in the equipment, and is also useful to check the tubes.

Air pressure source

If a compressor is selected for use, take into consideration the air consumption amount (approx. 30 Nℓ/min per scale). The graph below shows the discharged air amount and rated output as a rough guideline for selecting a compressor. Although the specific graph may vary depending on the compressor model, please use it as a reference.

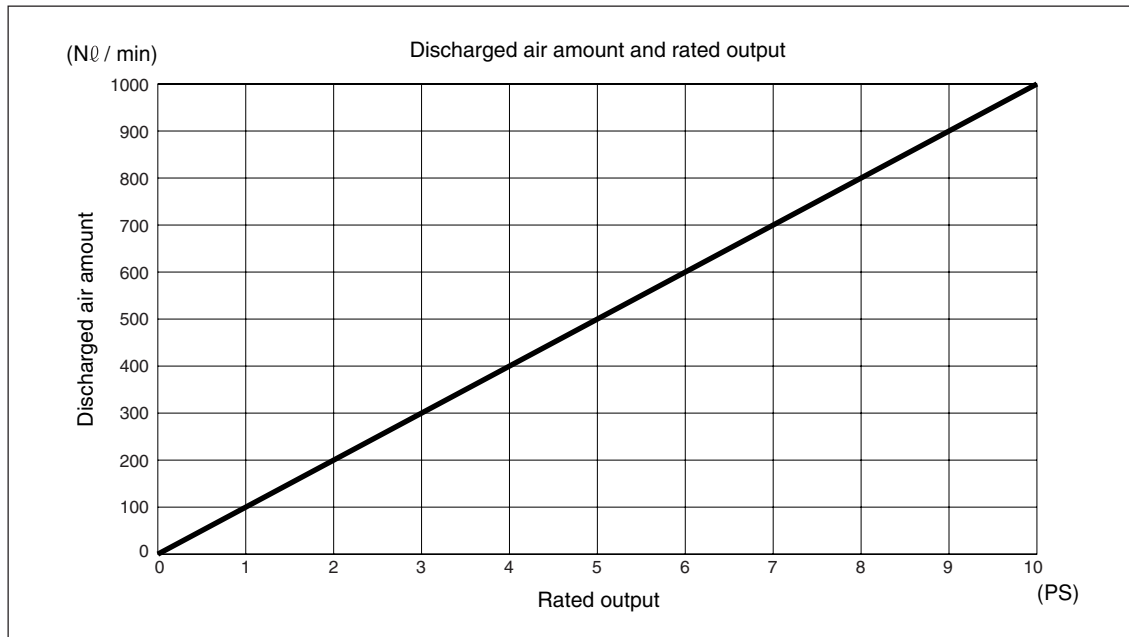

Fig. 4-3

4-2. Oil Lubrication

In the standard configuration, an M5 tap hole for air purging is provided in the end cap section of the scale. If using in the following severe environments where air purge alone is not sufficient, oil mist can be injected into the scale to reduce the effects.

The actual effects, however, will vary depending on operating conditions. Therefore, be sure to fully check the effects before using oil lubrication.

- Use in dusty area
- Use in locations close to coolants

Air Tube Route and Device Configuration

Prepare the devices as shown in the figure below, and air is injected into the scale by connecting the air tubes.

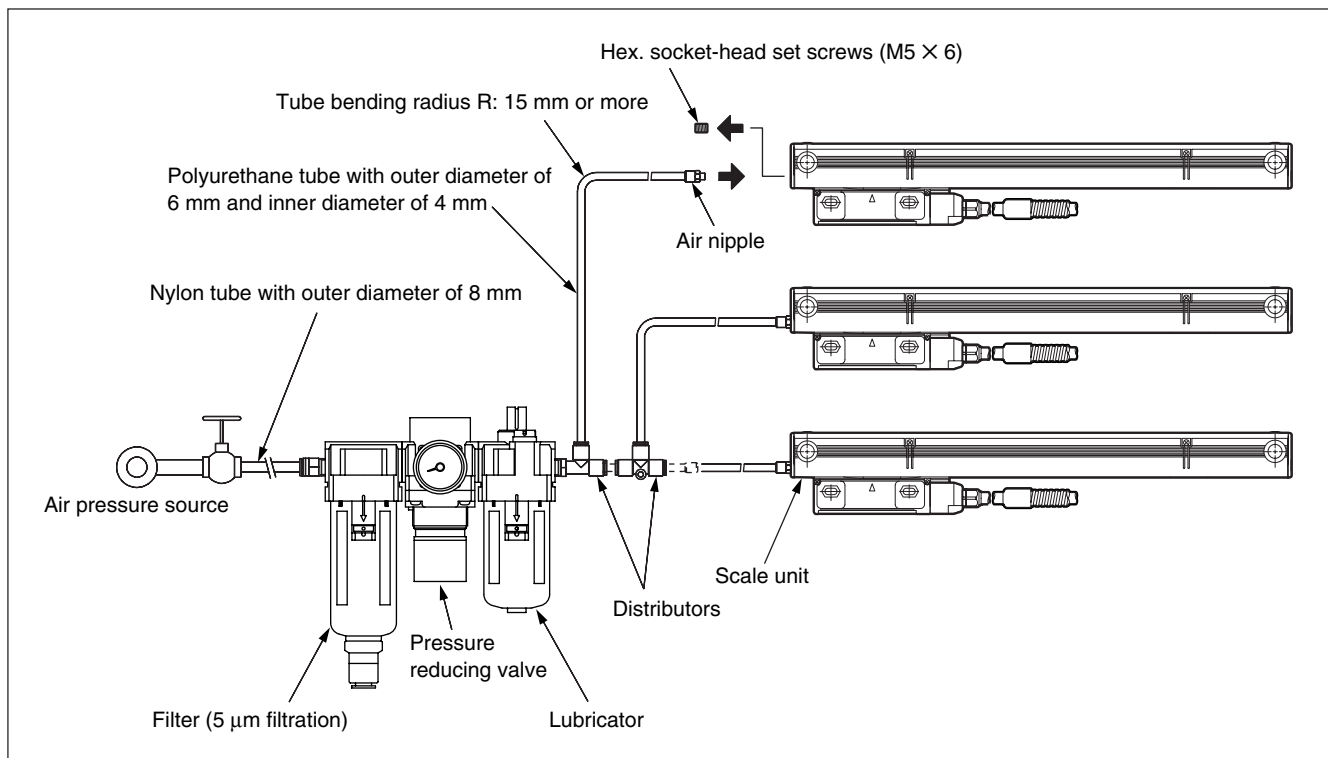

Fig. 4-4

The customer must obtain the air supply unit and input/output air tube.

Main components

Manufacturer	Model	Name	Quantity
SMC Corporation	AF3000-02C	Air filter	1
SMC Corporation	AL3000-02C	Lubricator	1
SMC Corporation	AR3000-02G-1	Regulator with 200 kPa pressure gauge	1
SMC Corporation	Y30L	Spacer assembly with L-type bracket	2

In side tube diameter: $\varnothing 8$, Out side tube diameter: $\varnothing 6$

The air filter should incorporate a float-type auto drain (NC) mechanism.

Use a drain tube with a diameter of at least 4 mm and length of 5 m or less. Set the tubes so that there is no rising.

■ Oil

① Use stainless AAA oil (kinetic viscosity #15) by Houghton,
or

② Turbine oil with no additives (viscosity #32) by Houghton

Performance cannot be guaranteed if other oils are used.

■ Lubricant amount

1 drop every 2 or 3 minutes (minimum adjustable amount by the lubricator)

5. Specifications

5-1. Scale

Item	Model name	SR74-XXX
Measuring length (ML)		70 to 2040 mm (26 types) 70, 120, 170, 220, 270, 320, 370, 420, 470, 520, 570, 620, 720, 770, 820, 920, 1020, 1140, 1240, 1340, 1440, 1540, 1640, 1740, 1840, 2040
Thermal expansion coefficient		$12 \pm 1 \times 10^{-6}/^{\circ}\text{C}$
Output signal		A/B, Reference point line driver signal (compliant with EIA-422) For details, see section 3-1, "Scale (SR74/75)."
Minimum phase differential time		Selectable from 50/100/150/200/250/300/400/500/650/1000/1250/2500/3000 ns (set at factory shipping)
Accuracy (at 20 °C)		3 + 3ML/1000 $\mu\text{m-p-p}$ or 5 + 5ML/1000 $\mu\text{m-p-p}$
Resolution		Selectable from 0.01, 0.05, 0.1, 0.5, and 1.0 μm (set at factory shipping)
Reference point		• None • Center point • Multi-point (40 mm pitch) • Reference mark (standard pitch: 20 mm) • User-selected point (1 mm pitch)
Power supply voltage		DC 4.75 - 5.25 V (At cable connection end)
Consumption current		200 mA (at 120 Ω terminal) or less
Inrush current		2 A max. (When the power supply rising time is 10 ms)
Maximum response speed		50 m/min (Resolution: 0.1 μm , Minimum phase difference: at 100 ns)
Vibration resistance		150 m/s^2 (50 Hz to 3 kHz)
Shock resistance		350 m/s^2 (11 ms)
Protective design grade		IP54 (Air purge not included), IP65 (Air purge included) For details, see section 4-1, "Air purge."
Other protections		Oil lubricant can also be used under severe environmental conditions. For details, see section 4-2, "Oil Lubrication."
Power supply protection		In the case of errors such as a reverse-connected power supply or over-voltage, the internal fuse is cut to protect the power being supplied and wiring.
Safety standards		FCC Part15 Subpart B Class A ICES-003 Class A Digital Device EN55011 Gp1 Class A, EN61000-6-2 Safety standards not applicable (60 V DC or less)
Operating temperature range		0 to +50°C
Storage temperature range		-20 to +55°C
Mass		Approx. 0.27 kg + 1.36 kg · m
Slider sliding resistance		1 N
Dimensions		See section 6, "Dimensional Diagrams."

The information here is subject to change without notice. When designing machines, please request the latest specifications from your nearest sales representative.

Multi-point reference signal and Reference mark reference signal positions

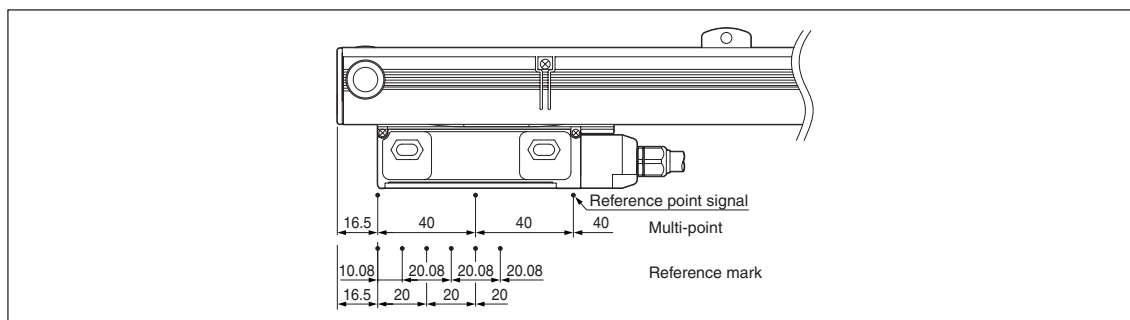

Fig. 5-1

Item	Model name SR75-XXX
Measuring length (ML)	70 to 2040 mm (26 types) 70, 120, 170, 220, 270, 320, 370, 420, 470, 520, 570, 620, 720, 770, 820, 920, 1020, 1140, 1240, 1340, 1440, 1540, 1640, 1740, 1840, 2040
Thermal expansion coefficient	$12 \pm 1 \times 10^{-6}/^{\circ}\text{C}$
Output signal	Incremental serial bidirectional signal, compliant with EIA-485 For details, see section 3-1, "Scale (SR74/75)."
Accuracy (at 20 °C)	3 + 3ML/1000 $\mu\text{m-p-p}$ or 5 + 5ML/1000 $\mu\text{m-p-p}$
Resolution	Selectable from 0.01, 0.05, 0.1, 0.5, and 1.0 μm (set at factory shipping)
Reference point	• None • Center point • User-selected point (1 mm pitch)
Power supply voltage	DC 4.75 - 5.25 V (At cable connection end)
Consumption current	200 mA (at 120 Ω terminal) or less
Inrush current	2 A max. (When the power supply rising time is 10 ms)
Maximum response speed	200 m/min (User-selected resolution setting)
Vibration resistance	150 m/s^2 (50 Hz to 3 kHz)
Shock resistance	350 m/s^2 (11 ms)
Protective design grade	IP54 (Air purge not included), IP65 (Air purge included) For details, see section 4-1, "Air purge."
Other protections	Oil lubricant can also be used under severe environmental conditions. For details, see section 4-2, "Oil Lubrication."
Power supply protection	In the case of errors such as a reverse-connected power supply or over-voltage, the internal fuse is cut to protect the power being supplied and wiring.
Safety standards	FCC Part15 Subpart B Class A ICES-003 Class A Digital Device EN55011 Gp1 Class A, EN61000-6-2 Safety standards not applicable (60 V DC or less)
Operating temperature range	0 to +50°C
Storage temperature range	-20 to +55°C
Mass	Approx. 0.27 kg + 1.36 kg · m
Slider sliding resistance	1 N
Dimensions	See section 6, "Dimensional Diagrams."

The information here is subject to change without notice. When designing machines, please request the latest specifications from your nearest sales representative.

5-2. Connecting Cables

Item	Model name	CH33-XXCP	CH33-XXCE	CH33-XXNP	CH33-XXNE
Type	Cable with unterminated end				
Conduit	Included (stainless steel) No conduit is used 100 mm from the slider-side connector and unterminated end			None	
Cable sheath	PVC	Polyurethane	PVC	Polyurethane	
Cable length	3, 5, 10, 15 m (standard product), Supports only 1 m units from 1 to 30 m (special-order product)				
Terminal processing	Unterminated end (standard product), Connector supporting various controller manufacturers can be attached (special-order product)				
Protective design grade	IP65 (scale-side connector)				
Safety standards and laws and regulations	Not applicable				
Operating temperature range	0 to +50°C				
Storage temperature range	-20 to +55°C				
Mass	Approx. 0.02 kg + 0.157 kg/m				
Recommended minimum bending radius (when there is repeated bending)	50 mm				
Recommended minimum bending radius (when there is no repeated bending)	Conduit unit: 25 mm, No conduit unit: 20 mm				
Dimensions	See section 6, "Dimensional Diagrams."				

The information here is subject to change without notice. When designing machines, please request the latest specifications from your nearest sales representative.

5-3. Accessories

SR74 / SR75

M4 × 10	Hex. socket-head cap screws	2	(For intermediate foot plate installation)
M4 × 20	Hex. socket-head cap screws	2	(For slider installation)
M8 × 16	Hex. socket-head cap screws	2	(For scale installation)
M4	Hex. nuts	2	(For slider rear surface installation)
Spacer: t = 0.1 mm		3	
Spacer: t = 1.0 mm		1	
Accuracy table		1	
Installation Manual		1	

6. Dimensional Diagrams

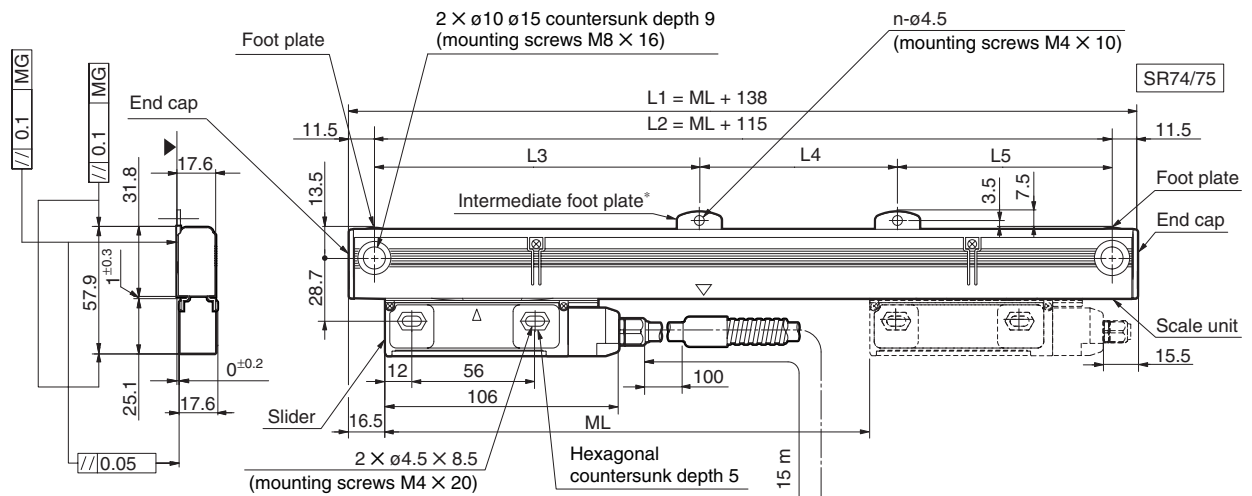

Unit: mm

ML	L1	L2	L3	L4	L5	n
70	208	185	-	-	-	0
120	258	235	-	-	-	0
170	308	285	-	-	-	0
220	358	335	-	-	-	0
270	408	385	-	-	-	0
320	458	435	-	-	-	0
370	508	485	-	-	-	0
420	558	535	-	-	-	0
470	608	585	-	-	-	0
520	658	635	-	-	-	0
570	708	685	-	-	-	0
620	758	735	-	-	-	0
720	858	835	417.5	-	417.5	1
770	908	885	442.5	-	442.5	1
820	958	935	467.5	-	467.5	1
920	1058	1035	517.5	-	517.5	1
1020	1158	1135	567.5	-	567.5	1
1140	1278	1255	627.5	-	627.5	1
1240	1378	1355	677.5	-	677.5	1
1340	1478	1455	727.5	-	727.5	1
1440	1578	1555	520	520	515	2
1540	1678	1655	550	550	555	2
1640	1778	1755	585	585	585	2
1740	1878	1855	620	620	615	2
1840	1978	1955	650	650	655	2
2040	2178	2155	720	720	715	2

ML : Measuring length

CL : Cable length

MG : Machine guide

* Intermediate foot plate: Installed in one location when $ML \geq 720$ mm and two locations when $ML \geq 1440$ mm

Notes

- The installation surface is indicated by ▲ surface.
- The screws indicated in the drawing are supplied as accessories.
- The reference point signal is output when the ▽ mark on the scale and △ mark on the slider are nearly aligned. There are no ▽ mark for multi-point and reference mark.
- The scale will be damaged if the slider moved outside the measuring length (ML). It is recommended that the machine movable length (stroke) be set at least 10 mm inward from each end of the measuring length (ML).

このマニュアルに記載されている事柄の著作権は当社にあり、説明内容は機器購入者の使用を目的としています。したがって、当社の許可なしに無断で複写したり、説明内容（操作、保守など）と異なる目的で本マニュアルを使用することを禁止します。

本手冊所記載的内容的版权归属 Magnescale Co., Ltd. 仅供购买本手冊中所记载设备的购买者使用。

除操作或维护本手冊中所记载设备的用途以外，未经 Magnescale Co., Ltd. 的明确书面许可，严禁复制或使本手冊的任何内容。

The material contained in this manual consists of information that is the property of Magnescale Co., Ltd. and is intended solely for use by the purchasers of the equipment described in this manual. Magnescale Co., Ltd. expressly prohibits the duplication of any portion of this manual or the use thereof for any purpose other than the operation or maintenance of the equipment described in this manual without the express written permission of Magnescale Co., Ltd.

Le matériel contenu dans ce manuel consiste en informations qui sont la propriété de Magnescale Co., Ltd. et sont destinées exclusivement à l'usage des acquéreurs de l'équipement décrit dans ce manuel.

Magnescale Co., Ltd. interdit formellement la copie de quelque partie que ce soit de ce manuel ou son emploi pour tout autre but que des opérations ou entretiens de l'équipement à moins d'une permission écrite de Magnescale Co., Ltd.

Die in dieser Anleitung enthaltenen Informationen sind Eigentum von Magnescale Co., Ltd. und sind ausschließlich für den Gebrauch durch den Käufer der in dieser Anleitung beschriebenen Ausrüstung bestimmt.

Magnescale Co., Ltd. untersagt ausdrücklich die Vervielfältigung jeglicher Teile dieser Anleitung oder den Gebrauch derselben für irgendeinen anderen Zweck als die Bedienung oder Wartung der in dieser Anleitung beschriebenen Ausrüstung ohne ausdrückliche schriftliche Erlaubnis von Magnescale Co., Ltd.

日本からの輸出時における注意

本製品 (および技術) は輸出令別表第1の16の項 (外為令別表16の項) に該当します。キャッチオール規制による経済産業省の許可要否につきましては、輸出者様にてご確認ください。

For foreign customers

Note: This product (or technology) may be restricted by the government in your country. Please make sure that end-use, end user and country of destination of this product do not violate your local government regulation.

Magnescale Co., Ltd.

45 Suzukawa, Isehara-shi, Kanagawa 259-1146, Japan