

## ■ Specifications

Model name	DF830SVR
Measuring range	30 mm
Resolution	0.1 μm
Accuracy (at 20°C)	1.7 μm
Measuring force (at 20°C)	Air pressure of 0.07 Mpa: 1.9 N or less in all directions Air pressure of 0.09 Mpa: 2.6 N or less in all directions
Maximum response speed	80 m/min
Reference point	Position at spindle movement of 1±0.5 mm
Reference point response speed	80 m/min
Output	Serial communication protocol
Spindle drive system	Air pressure ejection
Number of cycles tested	60 million (Depends on the evaluation test defined by Magnescale Co., Ltd.)
Protection grade (Not including interpolation box and connector)	IP53 When using the DZ830BV: IP67
Vibration resistance	100 m/s <sup>2</sup> (20 to 2000 Hz)
Impact resistance	1000 m/s <sup>2</sup> (11 ms)
Operating temperature	0 to 50°C
Storage temperature	-20 to 60°C
Power supply	DC +10 to +30 V
Power consumption	1.2 W or less
Mass	Approx. 80 g (Not including cable and interpolation box)
Cable length	2 m
Feeler	Carbide ball tip, Mounting screw M2.5
Accessories	Instruction Manual, Spanner

\* Use the CE34 that is sold separately for the output cable. (Cable length Max.20 m)

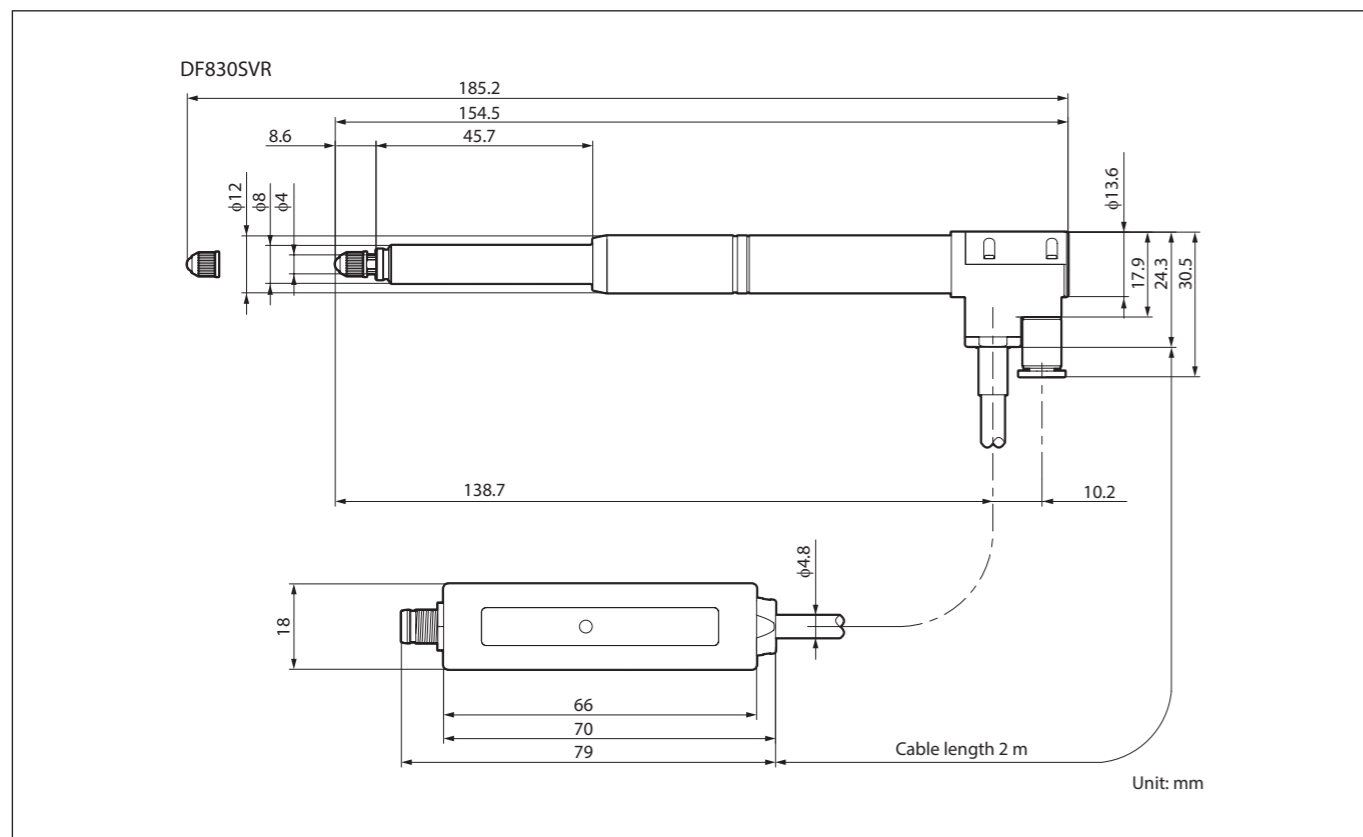

# Magnescale

## Digital Gauge

# DF830SVR

## Instruction Manual

Read all the instructions in the manual carefully before use and strictly follow them.

Keep the manual for future references.

### Safety Precautions

Magnescale Co., Ltd. products are designed in full consideration of safety. However, improper handling during operation or installation is dangerous and may lead to fire, electric shock or other accidents resulting in serious injury or death. In addition, these actions may also worsen machine performance.

Therefore, be sure to observe the following safety precautions in order to prevent these types of accidents, and to read these "Safety Precautions" before operating, installing, maintaining, inspecting, repairing or otherwise working on this unit.

### Warning Indication Meanings

The following indications are used throughout this manual, and their contents should be understood before reading the text.

#### Symbols requiring attention



#### Symbols prohibiting actions



**Warning** Failing to follow the precaution items given below may lead to severe injury or death.

- Do not damage, modify, excessively bend, pull on, place heavy objects on or heat the cable, as this may damage the cable and result in fire or electric shock.
- Do not disassemble or modify the unit, as this may result in injury or electric shock. These actions may also damage the internal circuitry.

**Caution** Failing to follow the precaution items given below may lead to injury or damage to surrounding objects.

- The unit does not have an explosion-proof structure. Therefore, do not use the unit in an atmosphere charged with inflammable gases as this may result in fire.

### ■ General precautions

- Before and during operations, be sure to check that our products function properly.
- Provide adequate safety measures to prevent damages in case our products should develop malfunctions.
- Use outside indicated specifications or purposes and modification of our products will void any warranty of the functions and performance as specified of our products.
- When using our products in combination with other equipment, the functions and performances as noted in this manual may not be attained, depending on operating and environmental conditions.

### [For U.S.A. and Canada]

THIS CLASS A DIGITAL DEVICE COMPLIES WITH PART15 OF THE FCC RULES AND THE CANADIAN ICES-003. OPERATION IS SUBJECT TO THE FOLLOWING TWO CONDITIONS.

- THIS DEVICE MAY NOT CAUSE HARMFUL INTERFERENCE, AND
- THIS DEVICE MUST ACCEPT ANY INTERFERENCE RECEIVED, INCLUDING INTERFERENCE THAT MAY CAUSE UNDERSIGNED OPERATION.

CET APPAREIL NUMÉRIQUE DE LA CLASSE A EST CONFORME À LA NORME NMB-003 DU CANADA.

Magnescale Co., Ltd.

45 Suzukawa, Isehara-shi, Kanagawa 259-1146, Japan

DF830SVR  
2-A01-974-1B

2020.6  
Printed in Japan  
©2015 Magnescale Co., Ltd.

## ■ Mounting Instructions

### Installation environment

- Do not use the unit in places where it may receive excessive shocks. Otherwise the inside of the unit may be damaged or the unit may become unable to produce normal output signals.
- Locate the measuring unit at least 10 cm away from a strong magnetic source. (The measuring unit must not be used in magnetic fields exceeding 5 mT.)
- Do not place the measuring unit where it is exposed to splash of water or oil.

### Mounting

- Be sure to turn off the power switch of the digital tolerance indicator before connecting or disconnecting the output cable.
- When attaching and removing the feeler, use the supplied spanner. Be careful not to apply torque exceeding 0.1 N·m to the spindle. This could lead to a breakdown. To prevent the feeler from becoming loose, it is recommended to either attach the supplied spring washer (nominal size: 2.5) or use a screw lock. (tightening torque reference value: 0.05–0.06 N·m)

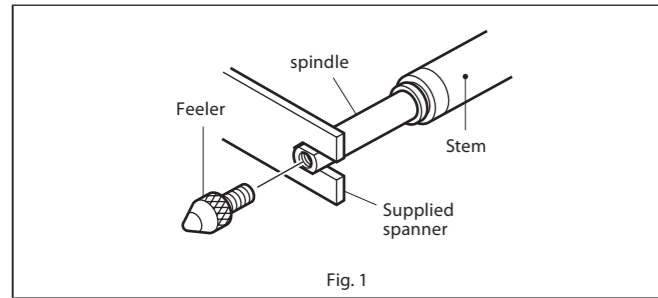

- Fix the cable in a suitable position to prevent possible cable breakage. Never handle the cable by forcibly pulling or bending it. (Inside bend radius 50 mm or more)
- The measuring accuracy depends on the mounting parallelism. Adjust the squareness to the measuring surface or the parallelism to the movement to within 0.02 mm/14 mm.
- After the stem is secured, do not apply force in the rotational direction. This could cause a failure.
- The measuring unit comprises ball bearings. Therefore, chucking the stem of the measuring unit too tightly when mounting may damage the spindle and prevent its smooth motion.
- Attach the stem by tightening a screw into the slot as shown in Fig. 2. Never attach by screw threading in the  $\phi 8$  mm hole vertical direction, pressing the stem, and then tightening with a screw. This could result in poor sliding and low precision.
- Be absolutely sure to chuck the stem part when mounting the measuring unit.
- Using Fig. 2 as a reference, select which holder to have ready at the mounting side.

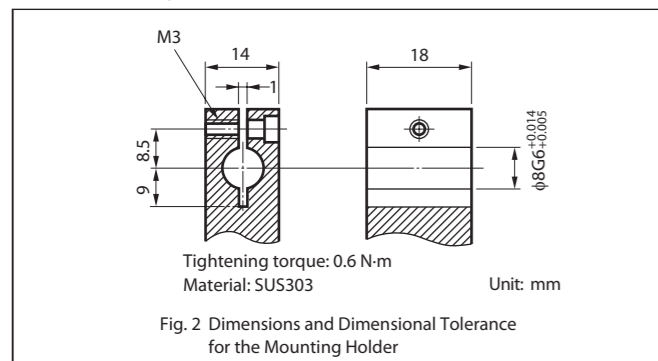

- When mounting onto a machine, use of the Flange Adaptor DZ830F (optional accessory) is recommended for preventing damage to the measuring unit due to over-tightening.
- For the mounting procedure, please refer to the Instruction Manual supplied with the DZ830F.

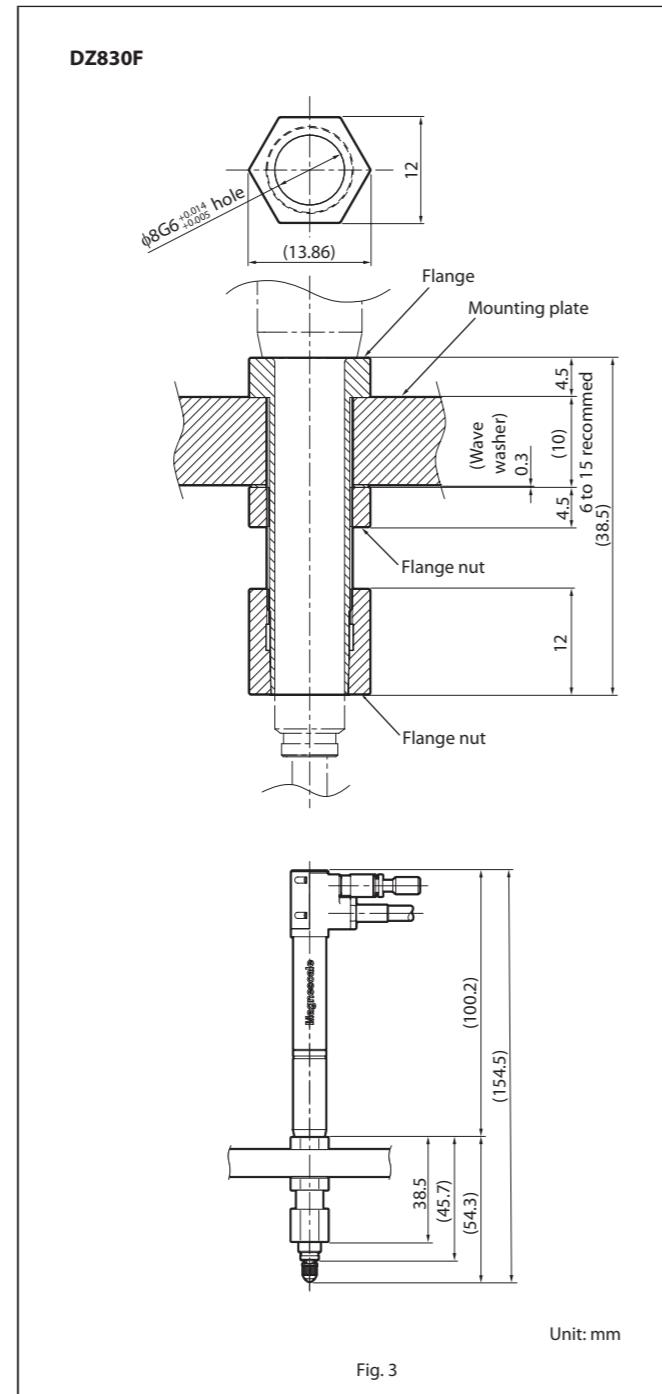

## ■ Maintenance

- Calibration is recommended every year.
- An anti-dust bellows available as an optional accessory can be mounted to the spindle part of this unit. Organic solvents, ozone, ultraviolet rays, and other adverse conditions in the ambient atmosphere can cause rapid deterioration of the anti-dust bellows. When using in these environments, replace anti-dust bellows periodically (every six months to one year).

## ■ When providing an IP67 protection grade

- Please use the optional DZ830BV bellows set.

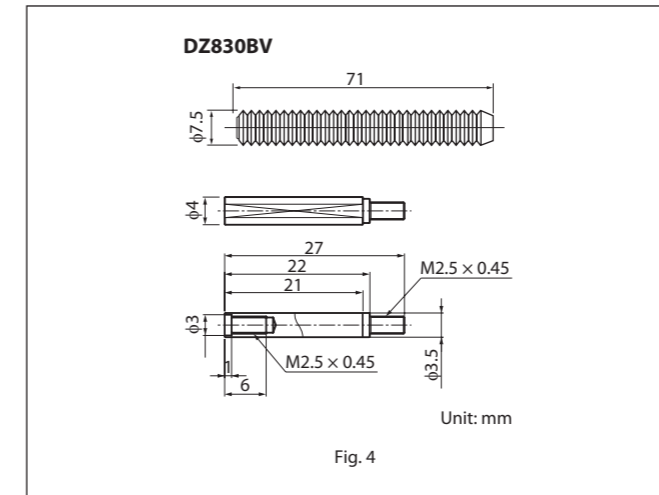

## ■ When driving the unit using air

After attaching the air tube, construct the air pressure circuit as shown in Fig. 5.

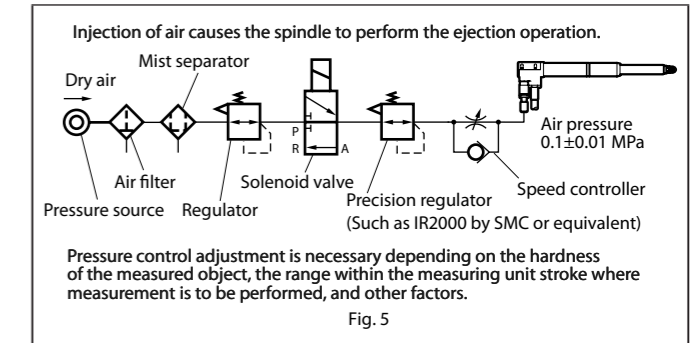

If the spindle ejection speed is too fast, an error may appear on the display the moment that the workpiece is touched. Excessive impact may dislodge the retainer inside the bearing, causing the measuring range to be reduced. In this case, use a speed controller as shown in Fig. 5 to adjust the spindle speed.

## ■ Troubleshooting

The operating status of the measuring unit can be checked using the LED indicator.

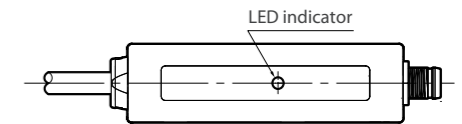

LED lighting color	Details	Remedial action
Lights in blue.	The power is turned on. Normal operation is now performed. The reference point has been detected.	-
Blinks in blue.	The power is turned on. The reference point standby status is established or the reference point is being detected.	When the reference point is used, turn on the power with the spindle contracted (in its initial state), and then move the spindle 1.5 mm or more. When the power is turned on with the spindle stopped near the reference point position, it may not be possible to detect the reference point or the reference point may shift. When the reference point will not be used, set the reference point use setting to OFF at the digital tolerance indicator.
Blinks in red.	The signal level of the measuring unit is abnormal.	After dealing with the factor suspected to be responsible for the alarm, turn the power back on.
Lights in red.	The maximum response speed has been exceeded. The signal level of the measuring unit is abnormal. Serial communication trouble has occurred. Normal operation cannot be performed due to the effects such as external noise etc.	If the same symptoms persist even after the power has been turned back on, the measuring unit or digital tolerance indicator might be malfunctioned.
Off	Power OFF	If the same symptoms persist even when the power has been turned on, the measuring unit or digital tolerance indicator might be malfunctioned.